

## IQ8Quad – OT, OT<sup>blue</sup>, O<sup>2</sup>T, OTG

- **Highest protection against false alarms**
- **Unambiguous fire detection through integrated multi-sensor technology**
- **Complete self-monitoring**
- **Short-circuit and open-circuit tolerant**
- **Signal classification to recognise signals not typical of fires through pattern recognition of fire parameters and multisensor evaluation**
- **Optimum adjustment to ambient conditions through configurable parameters**
- **Integrated fault, alarm and operating hours counter**
- **Extremely low quiescent current of 50 to 65µA**
- **Indicates detector contamination and implements quiescent value tracing in accordance with the current standards and directives**
- **Time-controlled deactivation of single sensor elements**



### The innovative detector generation

The new IQ8Quad detector generation not only combines state-of-the-art detection technology in a single unit but also sets new standards in terms of safety and effectiveness.

### Clever installation and secure investment

Although equipped with a flat-design housing, IQ8Quad detectors are provided with a spacious mounting base for flexible cabling. In addition, unused wires can be directly looped through the base.

Irrespective of the detector version, the standard IQ8Quad detector base can be used for installation. (In addition with the standard detector base, a relay base can be ordered separately.) Thus, installation coordination is facilitated and made more flexible. Detectors can be easily and conveniently removed and the loop is not disconnected during removal. Therefore, fire alarm systems and all their components remain active and operable, enabling short-circuit and open-circuit control within the loop even during installation.

As of tools 8000 version 1.11.0, sensor technology for detector types OT, Ot<sup>blue</sup> and O<sup>2</sup>T can be perfectly adjusted

to local requirements through configurable parameters. (parameter configuration for OTG detectors is being in process)

### The esserbus

With a line length of up to 3,500m and connecting options for a maximum of 127 devices, all advantages provided by loop technology can be used: highest operational reliability and maximum flexibility during installation coordination or during fire alarm system modifications. On account of decentralised intelligence, implemented in the detectors, and standard isolators, bus devices are not disconnected from the loop in the case of wire breaks or short-circuits. Spurs can be located on the esserbus without adding further modules, which considerably reduces installation expenses. In addition, mixed operation of IQ8Quad detectors and Series 9200 detectors can be set up without facing difficulties.

### Four times IQ8Quad - four times the right choice

- OT** The secure and intelligent optical heat detector for the early detection of fires
- OT<sup>blue</sup>** Optical heat detector to guarantee the early detection of high energy fires. The detector replaces the classic ionisation smoke detector and provides high sensitivity to reliably detect the smallest fire particles by using blue LED light instead of infrared light.
- O<sup>2</sup>T** Even in the most challenging conditions, two integrated optical smoke sensors with different scatter angles and additional heat sensor provide for optimum detection of light and dark smoke and prevent false alarms from being triggered.
- OTG** Multisensor detector with integrated optical smoke detector, heat detector and gas sensor for detecting carbon monoxide (CO) in order to identify fires ranging from smouldering fires to open fires. Additionally, life-threatening carbon monoxide levels can be detected in the environment.

## Schematic loop diagram:

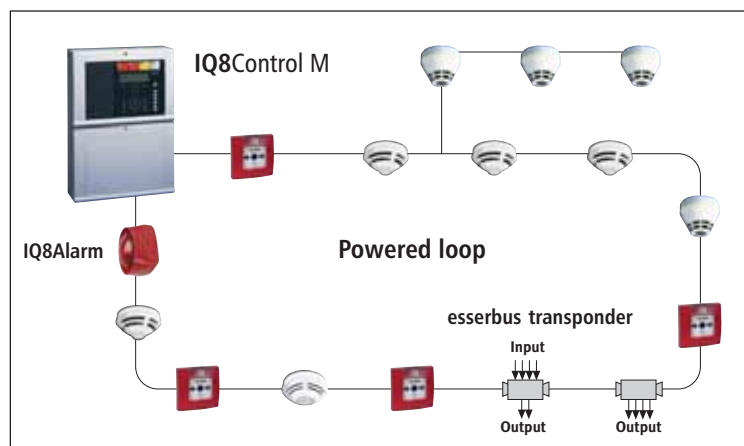

## Dimensions (mm):

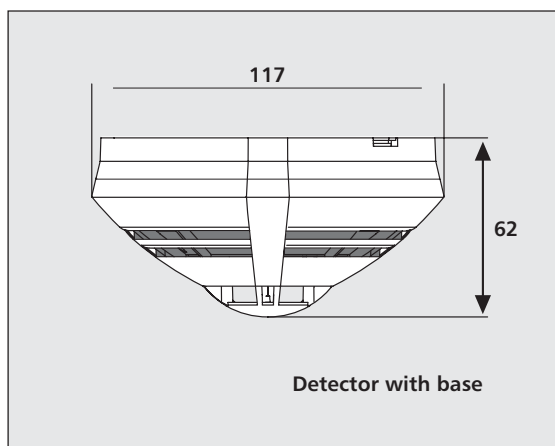

## Technical Data

Type	OT	OT <sup>blue</sup>	O <sup>2</sup> T	OTG
Part Number	802373	802375	802374	802473
Operating voltage	9 - 42 V DC	9 - 42 V DC	8 - 42 V DC	8 - 42 V DC
Quiescent current	approx. 50 µA	approx. 50 µA	approx. 60 µA	approx. 65 µA
Application temperature	-20 °C to +50 °C	-20 °C to +50 °C	-20 °C to +65 °C	-20 °C to +50 °C
VdS number	G 205070	G 205071	G 204061	G 205072
Detector specification	EN 54-7/5 A2	EN 54-7/5 A2	EN 54-7/5 B	EN 54-7/5 A2

## General technical data

Rated voltage	19 V DC
Max. monitoring range	110 m <sup>2</sup>
Max. monitoring height	12 m
Storage temperature	-25 °C to +75 °C
Type of protection	IP 43 (with 805570, 805572 or 805573)
Material	ABS
Colour	white, similar to RAL 9010
Weight	approx. 110 g
Dimensions w/o base (Ø x H)	117 x 49 mm
Dimensions with base (Ø x H)	117 x 62 mm

## Ordering data

## Part No.

OT Multisensor IQ8Quad	802373
OT <sup>blue</sup> Multisensor IQ8Quad	802375
O <sup>2</sup> T Multisensor IQ8Quad	802374
OTG Multisensor IQ8Quad	802473
Standard Detector Base IQ8Quad	805590
Detector Base with Relay Contact IQ8Quad	805591
Flush-Mount Housing for Detector Bases	805571
Labelling Field for Detector Bases	805576
IP Protection for Detector Bases	805570
Moisture-proof surface mount base adapter for IQ8Quad detector base	805572
Moisture protection seal for IQ8Quad detector base	805573

For further order information please refer to our "Fire Alarm Technology" Product Line Catalogue.

### Novar GmbH a Honeywell Company

Dieselstraße 2,  
D-41469 Neuss

Phone: +49 (0) 21 37 / 17-0 Administration  
+49 (0) 21 37 / 17-600 Customer Service Center  
Fax: +49 (0) 21 37 / 17-286

Internet:  
www.ackermann-clino.de

E-mail:  
info@ackermann-clino.de

### Novar Austria GmbH

Fernkorngasse 10,  
A-1100 Wien

Phone: +43 (0)1 / 6 00 60 30  
Fax: +43 (0)1 / 6 00 60 30-900

Internet:  
www.novar.at

E-mail:  
novar.austria@honeywell.com